

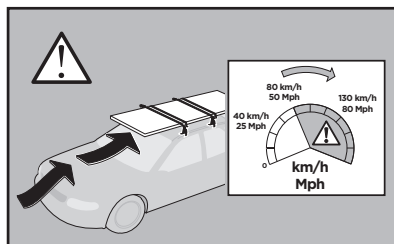

Thule Rapid System Kit 1400

> Instructions

- JMC Vigus, 4-dr Double Cab, 15-
- MITSUBISHI Challenger, 4-dr Double Cab, 11-
- MITSUBISHI Challenger, 5-dr SUV, 11-
- MITSUBISHI L200, 4-dr Double Cab, 05-09, 10-15
- MITSUBISHI Triton, 4-dr Double Cab, 05-09, 10-15

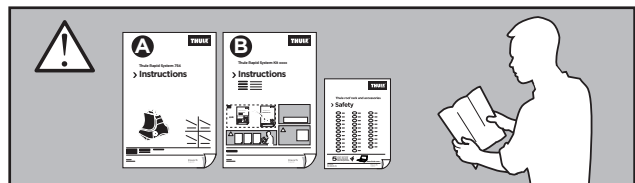
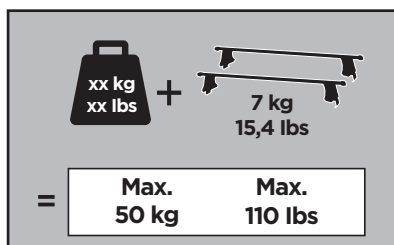
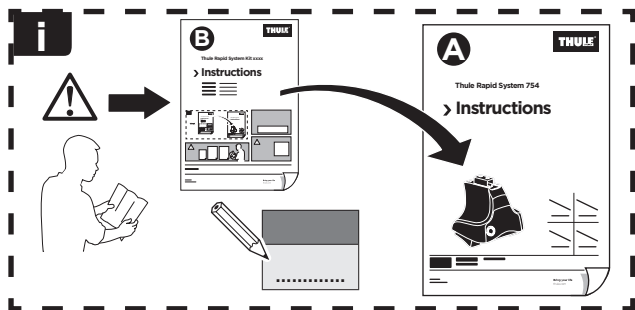

ISO 11154-E

141400
C.20150505
519-1400-05

Bring your life
thule.com

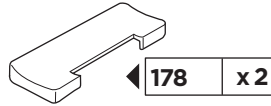
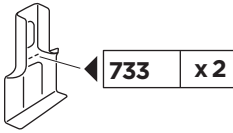

x1

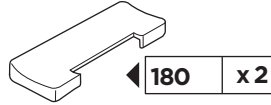
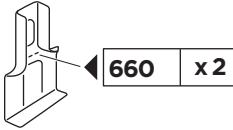

x1

1

	X (scale)	X (mm)	X (inch)
JMC Vigus , 4-dr Double Cab, 15-	40	1051	41 ³ / ₈
MITSUBISHI Challenger , 4-dr Double Cab, 11-	40	1051	41 ³ / ₈
MITSUBISHI Challenger , 5-dr SUV, 11-	40	1051	41 ³ / ₈
MITSUBISHI L200 , 4-dr Double Cab, 05-09, 10-15	40	1051	41 ³ / ₈
MITSUBISHI Triton , 4-dr Double Cab, 05-09, 10-15	40	1051	41 ³ / ₈

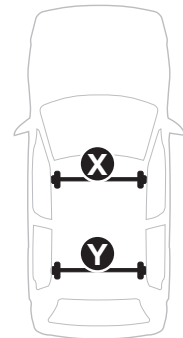
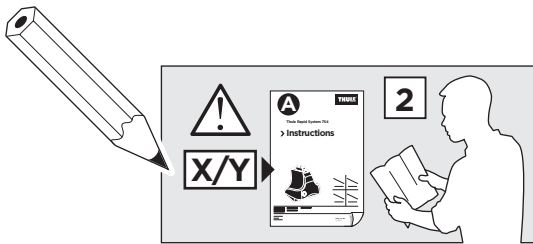

	Y (scale)	Y (mm)	Y (inch)
JMC Vigus , 4-dr Double Cab, 15-	31	991	37 ⁷ / ₈
MITSUBISHI Challenger , 4-dr Double Cab, 11-	34,5	996	39 ¹ / ₄
MITSUBISHI Challenger , 5-dr SUV, 11-	34,5	996	39 ¹ / ₄
MITSUBISHI L200 , 4-dr Double Cab, 05-09, 10-15	34,5	996	39 ¹ / ₄
MITSUBISHI Triton , 4-dr Double Cab, 05-09, 10-15	34,5	996	39 ¹ / ₄

2

JMC Vigus, 4-dr Double Cab, 15-

MITSUBISHI Challenger, 4-dr Double Cab, 11-

MITSUBISHI Challenger, 5-dr SUV, 11-

MITSUBISHI L200, 4-dr Double Cab, 05-09, 10-15

MITSUBISHI Triton, 4-dr Double Cab, 05-09, 10-15

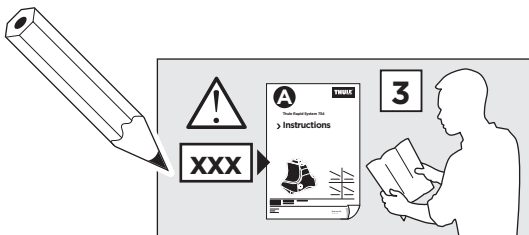
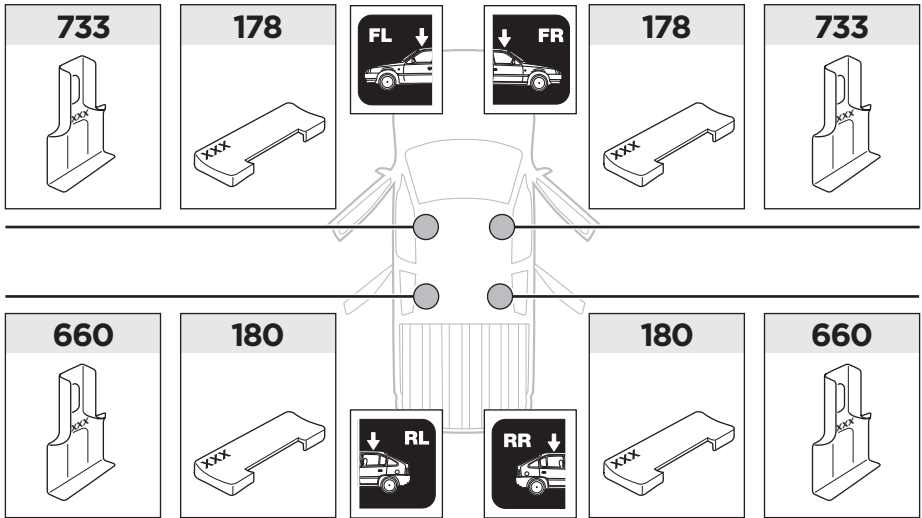

3

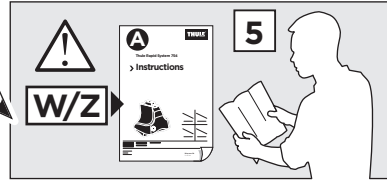

	W (mm)	Z (mm)	W (inch)	Z (inch)
JMC Vigus , 4-dr Double Cab, 15-	350	800	13 3/4	31 1/2
MITSUBISHI Challenger , 4-dr Double Cab, 11-	350	800	13 3/4	31 1/2
MITSUBISHI Challenger , 5-dr SUV, 11-	350	800	13 3/4	31 1/2
MITSUBISHI L200 , 4-dr Double Cab, 05-09, 10-15	350	800	13 3/4	31 1/2
MITSUBISHI Triton , 4-dr Double Cab, 05-09, 10-15	350	800	13 3/4	31 1/2

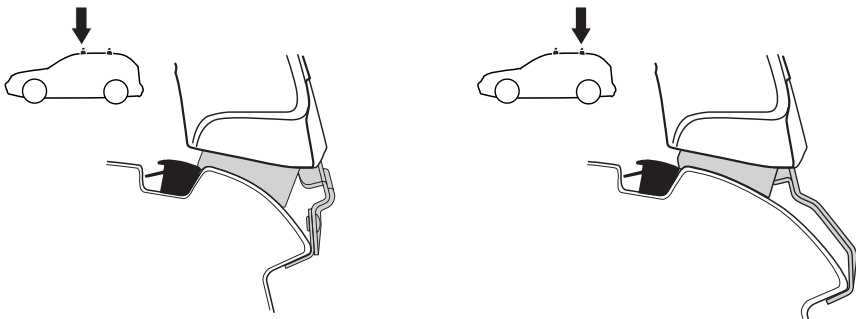
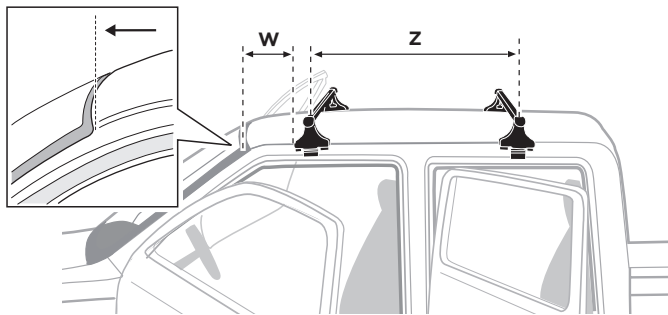

Thule Sweden AB, Box 69, 330 33 Hillerstorp, SWEDEN
 Thule Inc., 42 Silvermine Road, Seymour, Connecticut 06483, USA

info@thule.com
 Phone: 800-238-2388

www.thule.com

› PART OF THULE GROUP

© Thule Group 2015. All rights reserved.

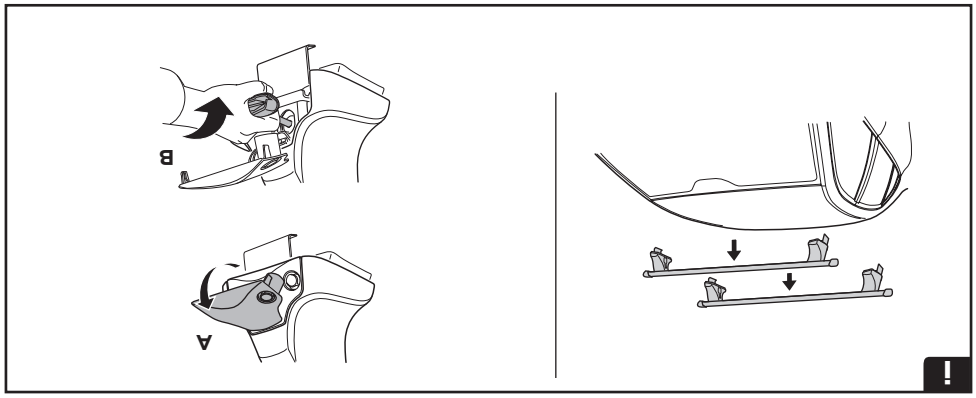
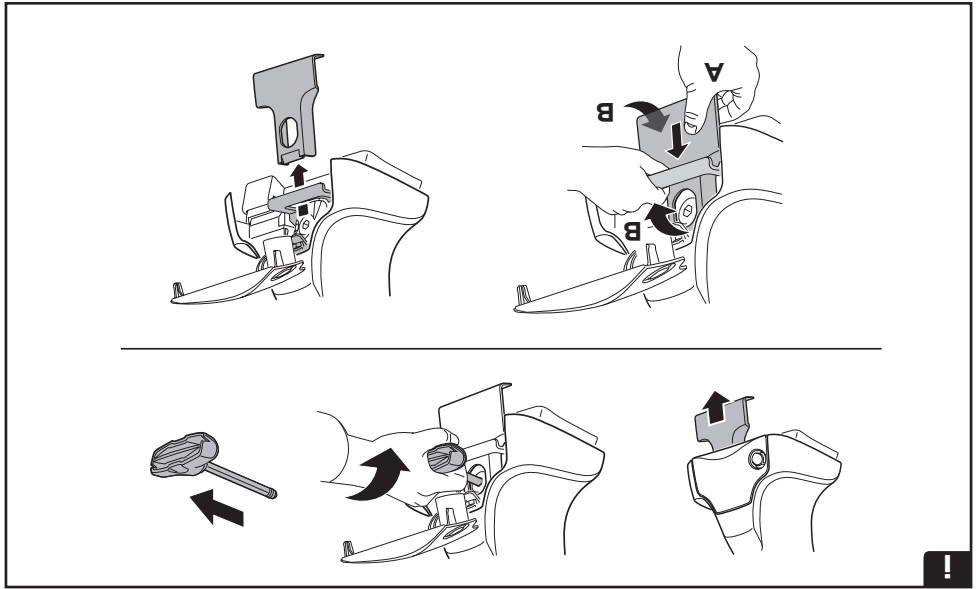

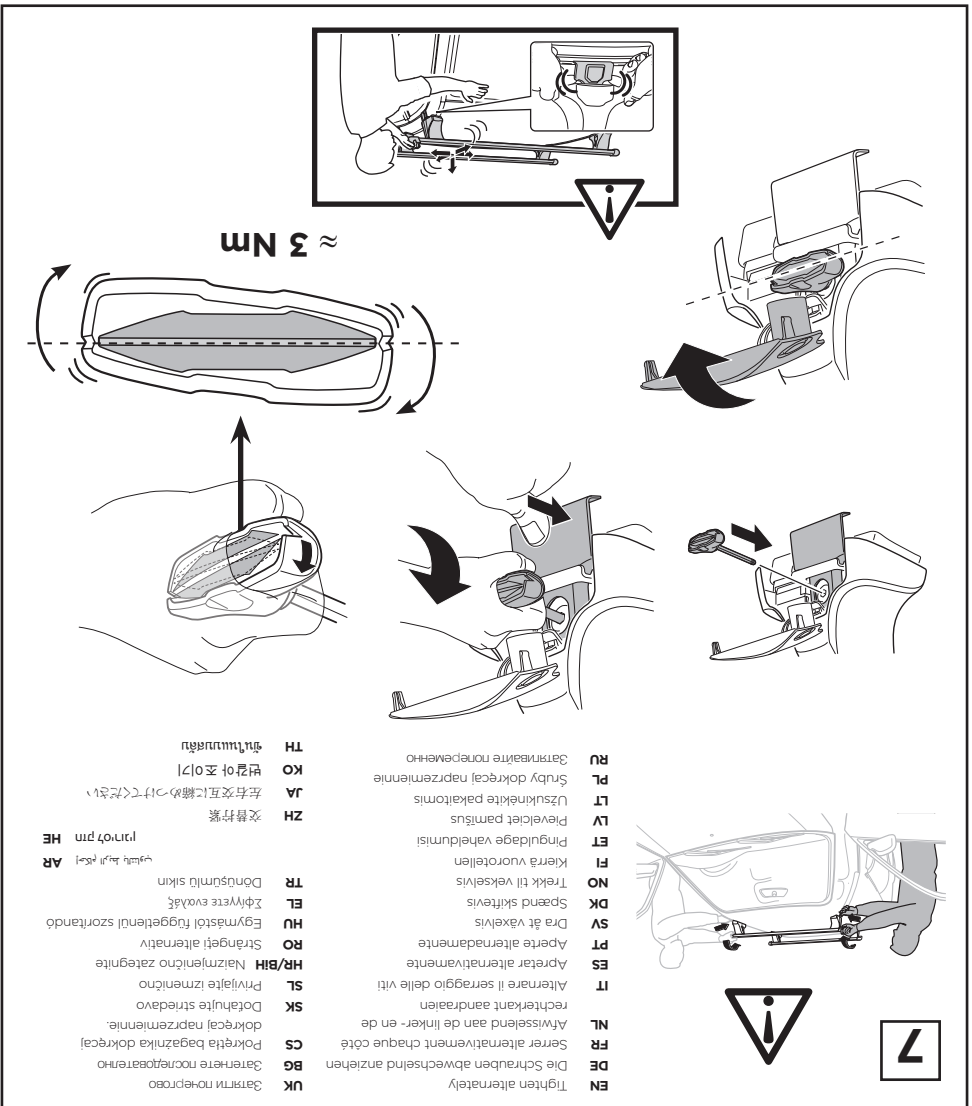
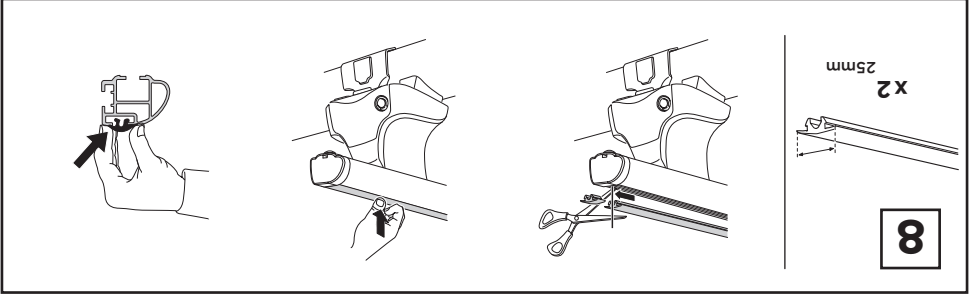

- UK Сабраіта норапрорава
- BG Забраһна норапрорава
- FR Serrer alternatifement chaque côté
- NL Afwisselend aan de linker- en de rechterkant aandraaien
- IT Alternare il serraggio delle viti
- ES Apertre alternativamente
- PT Aperte alternadamente
- SV Dra åt växelvis
- DK Spænd skiftevis
- NO Trekk til vekselvis
- FI Kierrä vuorotellen
- ET Pinguldage vaheldumisi
- LV Pieveicēt pamīšus
- LT Užsūknakite pakaitomis
- PL Srdub dokrecal naprzemiennie
- RU Забраһнаіта норапрорава
- TH 交替打緊
- JA 左右交互に締めつける
- KO 좌우交互로 조이기
- TH 交替打緊
- TR Dönüşümü sikkin
- EL Διφυγτε εναλλάξ
- HU Egyarástól függetlenül szorítandó
- RO Strângeti alternativ
- HR/BIH Naizmjenično zategnite
- SK Dotáňujte štriedavo
- SL Privijajte izmenično
- SL Privijajte izmenično
- SK Dotáňujte štriedavo
- HR/BIH Naizmjenično zategnite
- RO Strângeti alternativ
- HU Egyarástól függetlenül szorítandó
- EL Διφυγτε εναλλάξ
- TR Dönüşümü sikkin
- AR 交互打緊
- HE 交互打緊

≈ 3 Nm

7

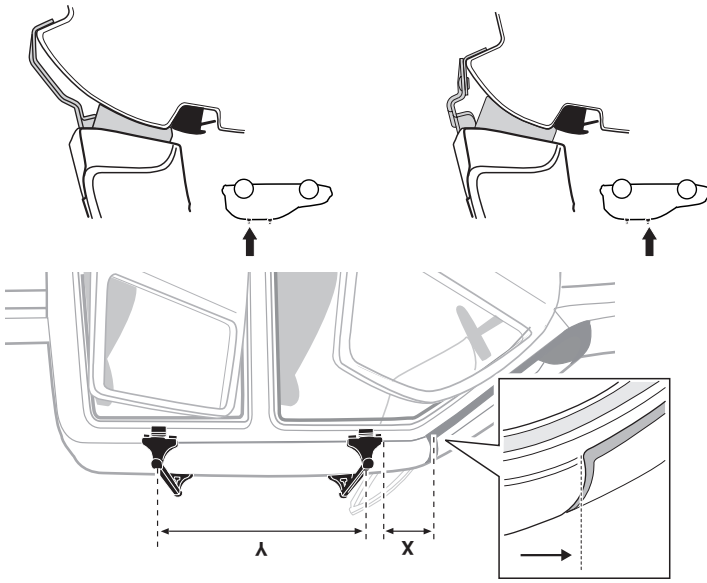

31 1/2	13 3/4	800	350	MITSUBISHI Triton, 4-dr Double Cab, 05-09, 10-15
31 1/2	13 3/4	800	350	MITSUBISHI L200, 4-dr Double Cab, 05-09, 10-15
31 1/2	13 3/4	800	350	MITSUBISHI Challenger, 5-dr SUV, 11-
31 1/2	13 3/4	800	350	MITSUBISHI Challenger, 4-dr Double Cab, 11-
31 1/2	13 3/4	800	350	JMC Vigus, 4-dr Double Cab, 15-

X mm X inch Y mm Y inch

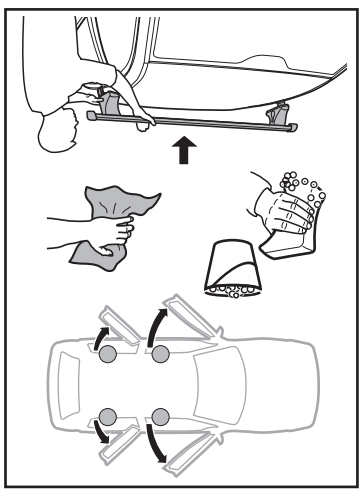
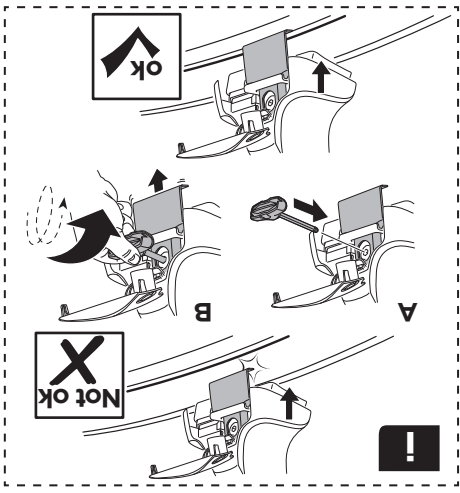

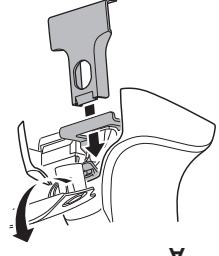
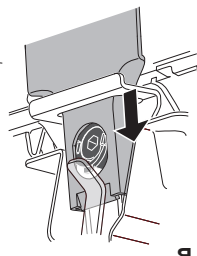
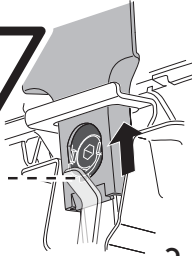
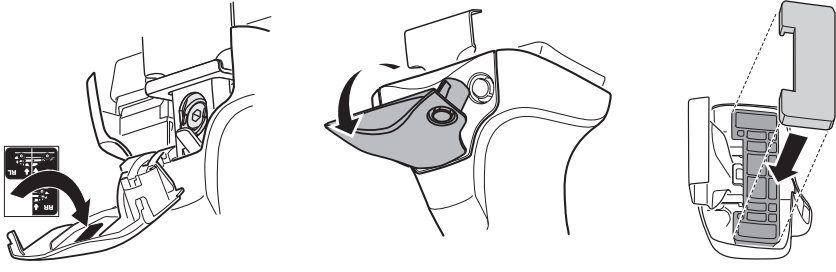

A

B

C

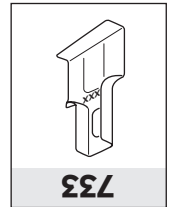
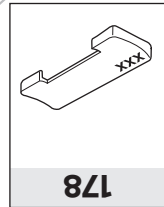
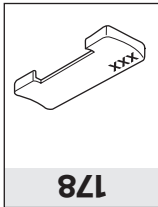
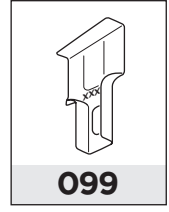
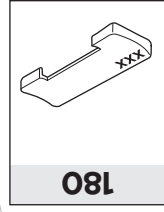
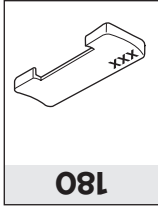

- JMC Vigus, 4-dr Double Cab, 15-
- MITSUBISHI Challenger, 4-dr Double Cab, 11-
- MITSUBISHI Challenger, 5-dr SUV, 11-
- MITSUBISHI L200, 4-dr Double Cab, 05-09, 10-15
- MITSUBISHI Triton, 4-dr Double Cab, 05-09, 10-15

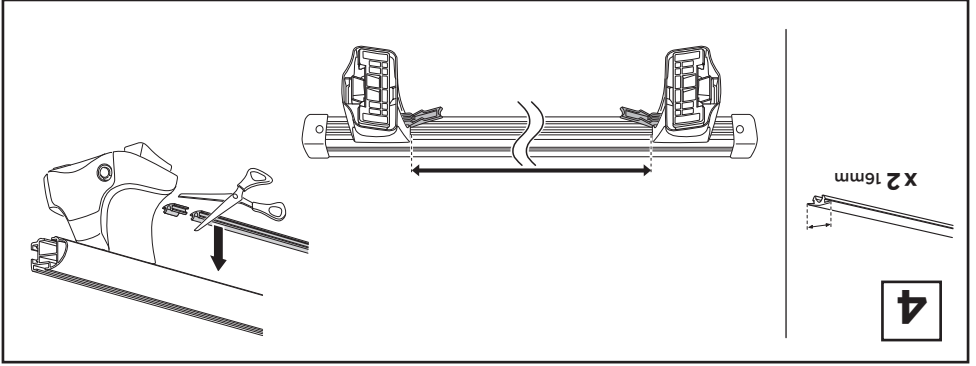

996	39 1/4	MITSUBISHI Triton, 4-dr Double Cab, 05-09, 10-15
996	39 1/4	MITSUBISHI L200, 4-dr Double Cab, 05-09, 10-15
996	39 1/4	MITSUBISHI Challenger, 5-dr SUV, 11-
996	39 1/4	MITSUBISHI Challenger, 4-dr Double Cab, 11-
991	37 7/8	JMC Vigos, 4-dr Double Cab, 15-

Y inch Y mm

1051	41 3/8	MITSUBISHI Triton, 4-dr Double Cab, 05-09, 10-15
1051	41 3/8	MITSUBISHI L200, 4-dr Double Cab, 05-09, 10-15
1051	41 3/8	MITSUBISHI Challenger, 5-dr SUV, 11-
1051	41 3/8	MITSUBISHI Challenger, 4-dr Double Cab, 11-
1051	41 3/8	JMC Vigos, 4-dr Double Cab, 15-

X inch X mm

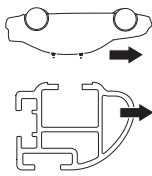
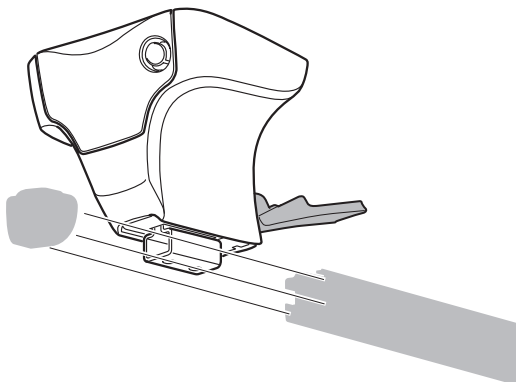
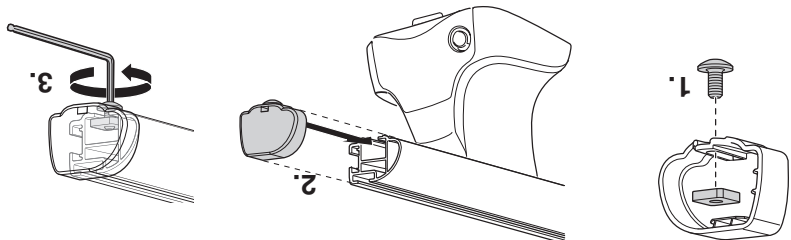

- X1 5mm Allen key
- X4 screws
- X4 battery cover tabs
- X2 battery covers

2

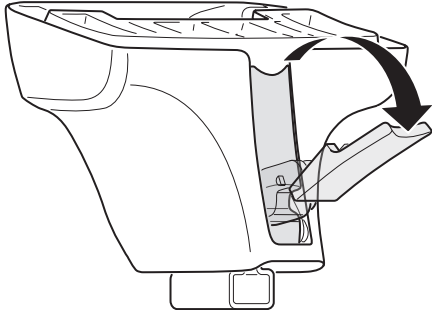

1

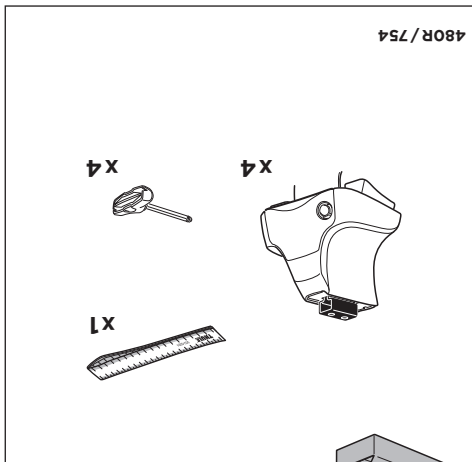
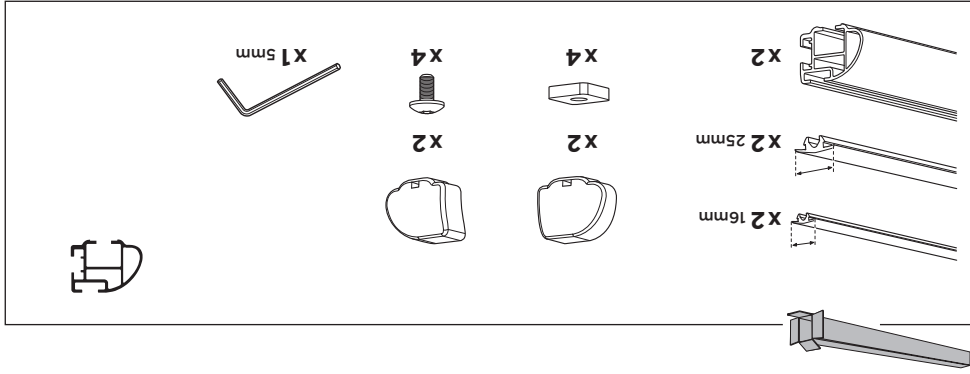
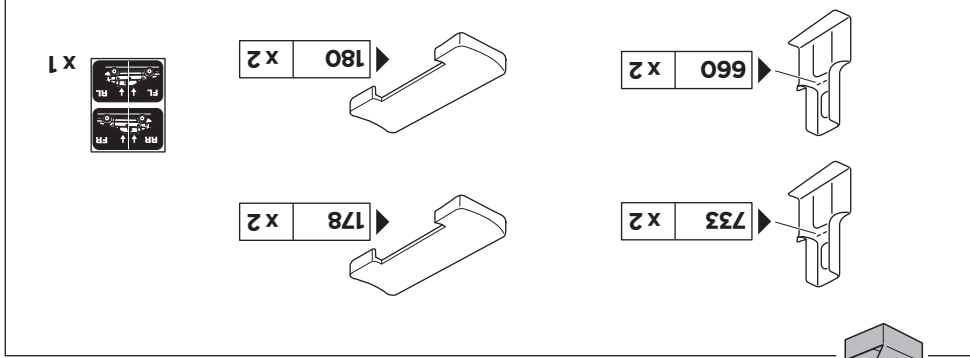

480R/754

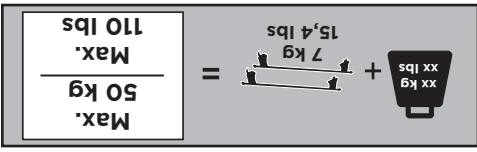
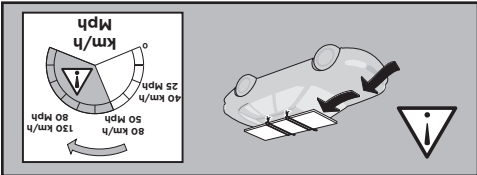
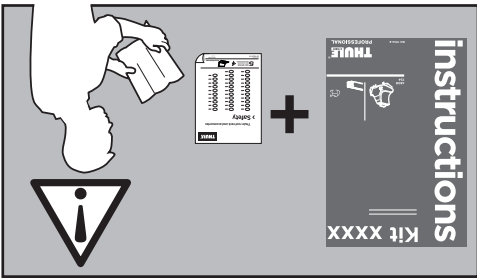

instructions

Kit 1400

- JMC Vigus, 4-dr Double Cab, 15-
- MITSUBISHI Challenger, 4-dr Double Cab, 11-
- MITSUBISHI Challenger, 5-dr SUV, 11-
- MITSUBISHI L200, 4-dr Double Cab, 05-09, 10-15
- MITSUBISHI Triton, 4-dr Double Cab, 05-09, 10-15

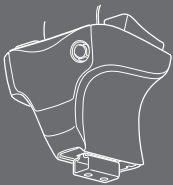

480R
754

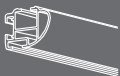

ISO 11154-E

PROFESSIONAL

THULE
SWEDEN